



Part no.: 53800131
BTP800M
Loop guard

Figure can vary

Contents

- Technical data
- Dimensioned drawings

Part no.: 53800131 – BTP800M – Loop guard

Technical data

Basic data

Suitable for	BTF815M mounting bracket BTF830M mounting bracket
--------------	--

Mechanical data

Dimension (W x H x L)	160 mm x x 169 mm
Net weight	600 g
Housing color	Black
Mounting device material	Metal

Classification

eCl@ss 8.0	27279202
eCl@ss 9.0	27273701

Dimensioned drawings

All dimensions in millimeters

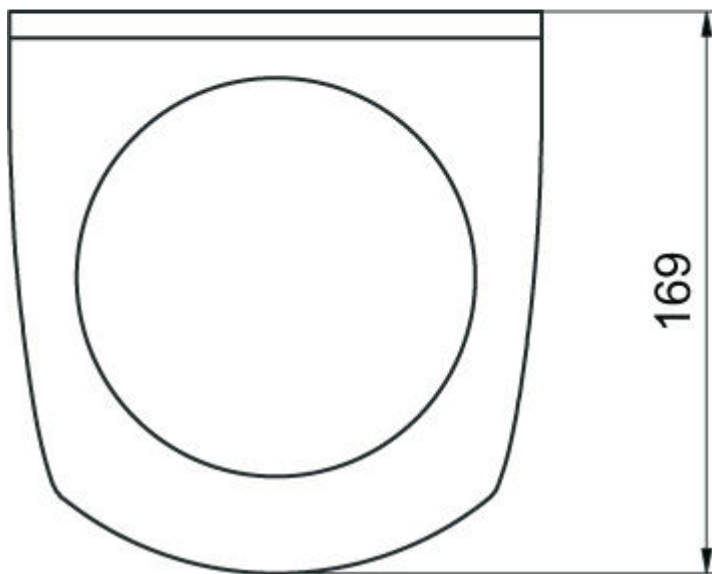
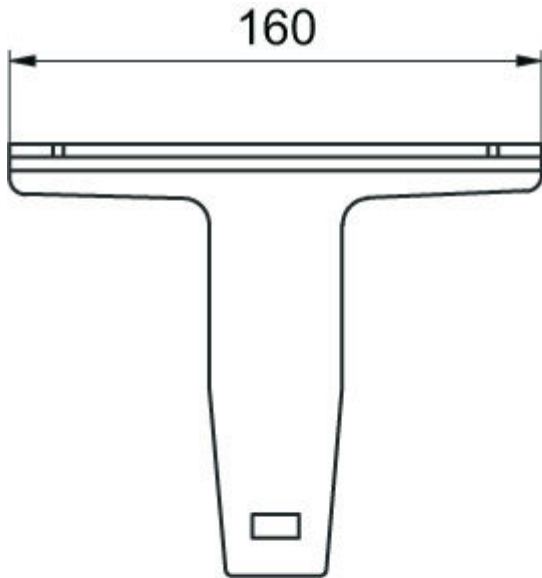

Example: loop guard mounting



Part no.: 53800131 – BTP800M – Loop guard

- 1 BTF815M mounting bracket for floor mounting (only with BTU800M mounting system)
- 2 BTU800M mounting system
- 3 Loop guard BTP800M
- 4 Safety sensor